

# H4EKO-D

USER MANUAL



**OPOP**



**CONTENT**

<b>1. INTRODUCTION .....</b>	<b>3</b>
<b>2. BOILER CHARACTERISTIC .....</b>	<b>3</b>
<b>3. TECHNICAL DESCRIPTION .....</b>	<b>3</b>
<b>4. TECHNICAL PARAMETERS .....</b>	<b>4</b>
<b>5. LIST OF SPARE PARTS .....</b>	<b>7</b>
<b>7. BOILER ASSEMBLY .....</b>	<b>9</b>
<b>8. CONNECTION OF THE COOLING LOOP .....</b>	<b>10</b>
<b>9. ELECTRIC HEATER INSTALLATION .....</b>	<b>10</b>
<b>10. ELECTRIC SCHEME.....</b>	<b>11</b>
<b>11. HYDRAULIC SCHEME .....</b>	<b>12</b>
<b>12. CONTROL UNIT .....</b>	<b>14</b>
<b>13. BASIC DUNCTION OF THE CONTROL UNIT .....</b>	<b>15</b>
<b>14. FITTERS MENU .....</b>	<b>17</b>
<b>14. BASIC SETUP OF THE CONTROL UNIT .....</b>	<b>18</b>
<b>15. IGNITING .....</b>	<b>19</b>
<b>16. WORK.....</b>	<b>19</b>
<b>17. FUEL LOADING .....</b>	<b>19</b>
<b>18. EXTINCTION .....</b>	<b>20</b>
<b>19. MAINTENANCE .....</b>	<b>20</b>
<b>20. SAFETY INSTRUCTIONS.....</b>	<b>21</b>
<b>21. MEASURES IN CASE OF FAILURE .....</b>	<b>23</b>
<b>22. ENERGY EFFICIENCY.....</b>	<b>25</b>
<b>23. IDENTIFICATION MARKS .....</b>	<b>26</b>
<b>24. REGULATIONS AND STANDARDS .....</b>	<b>29</b>
<b>25. WASTE DISPOSAL .....</b>	<b>29</b>
<b>26. WARRANTY CONDITIONS.....</b>	<b>29</b>
<b>27. WARRANTY CARD.....</b>	<b>31</b>
<b>28. DECLARATION OF CONFORMITY .....</b>	<b>32</b>

## 1. INTRODUCTION

Dear customer,

We greatly appreciate the fact that you have chosen the product from our product range and have become one of our customers. We wish you real pleasure with our product. We hope our product will serve you for a long time. All employees of our company contribute to this. Please read the operating instructions thoroughly and, if necessary, do not hesitate to ask us, we will be happy to advise you on the operation of the boiler.

## 2. BOILER CHARACTERISTIC

The H4xx EKO-D steel hot-water boiler of the H4xx EKO-D series is designed for floor and central heating of family houses or suitable production plants with a maximum hydrostatic water height of 20 m. The H4xx EKO-D boiler is designed for combustion of solid fuels, ie piece wood. Use of other substances or materials is not permitted. The boiler must be connected to the chimney corresponding to the boiler output and with the required minimum draft according to the user manual.

For proper boiler operation, in addition to expert installation, care must be taken to ensure that the boiler is properly serviced and regularly cleaned, as described below in this manual. This boiler has been certified by the Engineering Test Institute in Brno according to ČSN EN 303-5 and meets the strictest criteria for solid fuel combustion as it is classified in the highest emission class and also meets the Ecodesign standard.

## 3. TECHNICAL DESCRIPTION

H4xx EKO-D boilers are gasification boilers designed for combustion of wood. In the filling chamber of the boiler is a refractory nozzle that transmits the flame to the back of the boiler, to the heat exchanger, and then to the chimney. Exhaust fan is located at the outlet of the boiler flue, ensuring ideal combustion under almost all conditions. This is controlled by a boiler control unit located in its front section.

The combustion air supply is provided by the primary flaps (on the left and right sides of the boiler) and the secondary flap (front of the boiler). Primary flaps ensure the correct boiler output, while the secondary flap regulates the residual oxygen content in the boiler to optimize combustion with the lowest carbon dioxide and nitric oxide emissions.

On the top of the boiler you will find a filling and a cleaning door. Make sure that they are tightly closed during boiler operation. When combustion of wood in gasification boilers generates a large amount of smoke, which accumulates in the filling chamber under the filling door during the combustion process and gradually leaves through the nozzle into the heat exchanger. Do not open any of the doors during the burning process until there is only a small burning layer of remaining wood in the boiler, to which you can then re-fill the new fuel. More about heating in chapters "Ignition", "Operation", "Fuel loading", "Extinction".

On the side of the boiler you will find a pull rod that controls the exhaust flap to ensure that the smoke is drawn from the filling chamber so that no smoke escapes into the room when the door is opened. Do not open the door during the burning process, it is better to wait until the wood is burned on the residual hot layer that does not smoke. Then simply open the door and add new fuel. For more information, see "Fuel loading".

The side walls of the filling chamber are fitted with cover plates to protect the boiler walls from harmful substances that arise during combustion. These cover sheets are removable, but they must always be placed in the boiler during the burning.

Under the refractory nozzle is a combustion chamber. This is where the flame from the filling chamber goes down where the entire combustion process is completed. The combustion chamber is lined with fireclay bricks that capture residual amount of dust particles that would otherwise end up in the air. You can access the combustion chamber by opening the lower door. This way, you will also sweep the remaining ash out of the boiler.



All doors must be closed during boiler operation. If you leave any of the doors unsealed, flue gas leaks into the room, which can cause damage to person or property. Always make sure before the heating season that the door is properly closed and that it seals properly.

Behind the combustion chamber there is a plate exchanger of the boiler, fitted with turbulators to reduce the chimney temperature and the amount of dust particles in the air. The boiler is very simple in its construction, but still meets the strictest emission standards.

## 4. TECHNICAL PARAMETERS

Technical parameters		Boiler size	Boiler size	Boiler size
Name of the data	Unit	H416 EKO-D	H420 EKO-D	H425 EKO-D
Rated heat output	[kW]	16	20	25
Efficiency	[%]	90	90	90,2
Required chimney draft	Pa	12		
Weight	[kg]	265		
Ekodesign		yes	yes	yes
Boiler class according to EN 303-5		5	5	5
Volume of water	[ l ]	33	33	54
Chimney outlet diameter	[mm]	130	130	130
Fuel consumption	[kg/hod]	4,1	5,1	6
Heating water temperature range	[°C]	65 - 85	65 - 85	65 - 85
Fuel shaft volume	[ l ]	42	62	82
Dimensions of filling space	[cm]	35 x 22	35 x 32	35 x 42
Length of logs	[cm]	33	33	40
Combustion duration at max output	[hod]	> 4	> 4	> 4
The flue gas temperature at Nom. heat. output	[°C]	137	130	130
Maximum pressure of heating water	[MPa]	0,2	0,2	0,2
Testing pressure of heating water	[MPa]	0,4	0,4	0,4
Warranty fuel		hardwood, logs	hardwood, logs	hardwood, logs
Water content in fuel	[%]	H2O max. 20%	H2O max. 20%	H2O max. 20%
Mass flow of flue gas	[kg/s]	0,01	0,0147	0,0147
CO at 10% O2	[mg/m3]	136	-	92
Dust at 10% O2	[mg/m3]	52	-	31
Electrical IP	IP	20	20	20
Electrical power	[W]	11	22	22
Recommended buffer tank size *[1]	[l]	1000	1000	1000
Voltage supply	[V/A]	230/2	230/2	230/2

\*[1] The actual size of the buffer tank must be calculated by the designer.



Fuel consumption is directly dependent on the quality and type of fuel used, as well as maintaining the cleanliness of the internal heat exchange surfaces of the boiler. The smaller the chopped wood is used, the greater the boiler output is reached, but the burning time per one loading is shortened. On the contrary, if we need less power, we can use thicker wood to extend burning time on one loading. The position of the primary and secondary air flaps and the speed of the fan also affect the burning time.

**Dimensions of the boiler:**

		H416 EKO-D	H420 EKO-D	H425 EKO-D
Variant A: Outlet / Inlet sleeve (male thread)		G1 1/4"	G1 1/4"	G1 1/4"
Variant B: flange, new boiler for old				
Cooling loop connection (internal thread)		G 1/2"	G 1/2"	G 1/2"
Connection for draining and filling (internal thread)		G 1/2"	G 1/2"	G 1/2"
Connection for mounting the power control (internal thread)		G 3/4"	G 3/4"	G 3/4"
A - total boiler height	[mm]	964	964	964
B – total depth of the boiler	[mm]	1085	1085	1085
C – boiler width	[mm]	498	598	698
D – location of smoke flue	[mm]	635	635	635
E – the location of the water inlet	[mm]	109	109	109
F – the location of the water outlet	[mm]	791	791	791
H – placing a cooling loop	[mm]	238	238	238
I – location of the heater	[mm]	173	173	173
J – location of the drain valve	[mm]	77	77	77
Wall thickness of boiler body (water / flame)	[mm]	5	5	5
Wall thickness of the boiler body (water)	[mm]	3	3	3

**Description of boiler parts:**

Position	Part name
1	Main switch
2	Ashtray door
3	Door fitting
4	Cleaning Door
5	Exhaust fan
6	Control unit
7	Connection board
8	Secondary air regulation
9	Primary air regulation
10	Chimney flap control
11	Cleaning hole
12	Cooling loop
13	Electric heater inlet
14	Fireclay nozzle
15	Turbulator
16	Cleaning flap
17	Smoke flap
18	Filling shaft spacers
19	Filling shaft
20	Combustion chamber

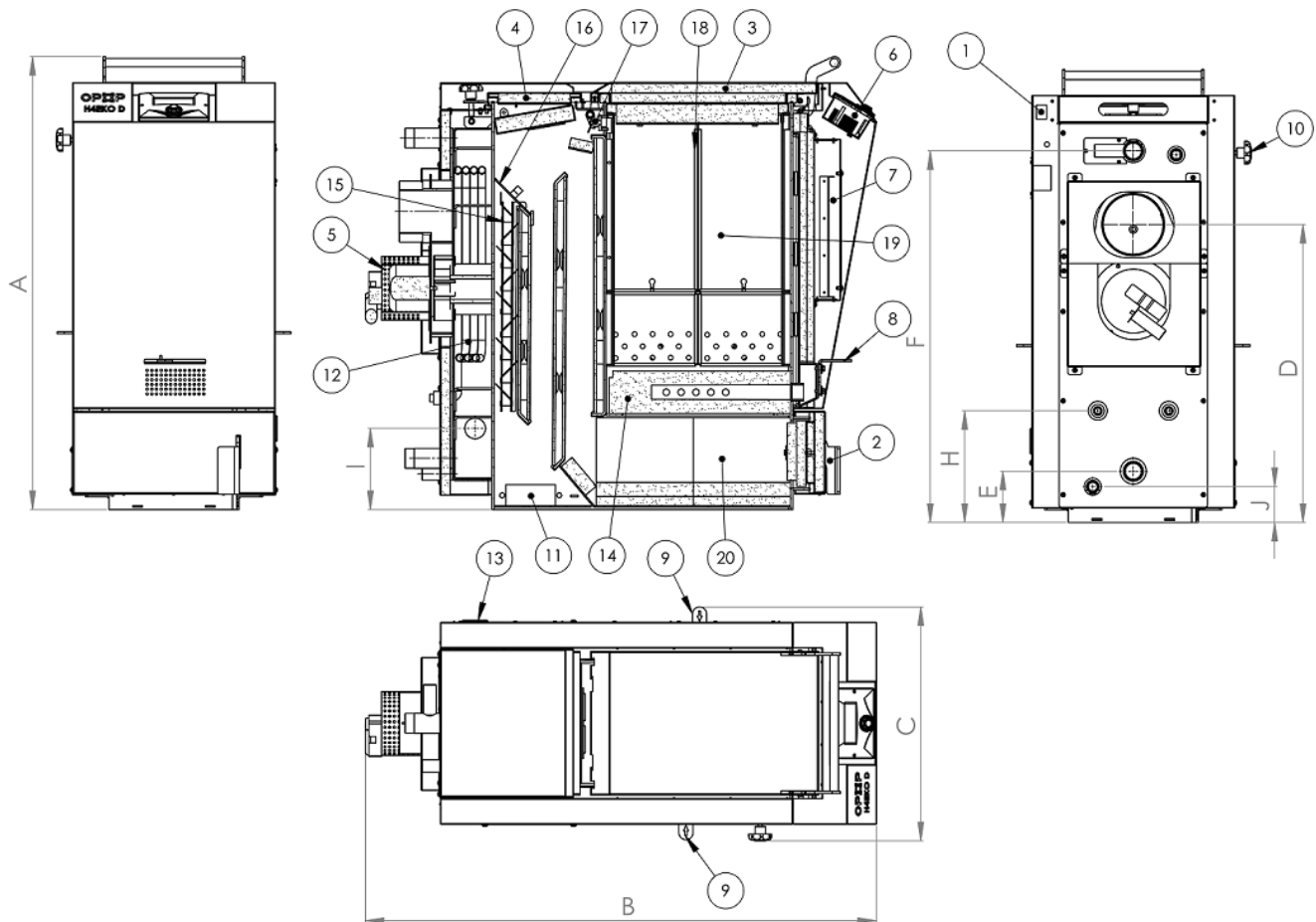
**Front of the boiler:**

- Control unit
- Secondary air flap
- Combustion chambre door

**Back side of the boiler:**

- CH sensor sink
- Safety sensor sink
- Heated water outlet
- Chimney outlet
- Flue gas temperature sensor
- Exhaust fan
- Cooling loop inlet and outlet (interchangeable)
- Cooling loop sensor sink
- Cold water inlet
- Filling valve inlet

**Left side of the boiler:**

- Primary air flap
- Filling chamber flap
- Cleaning closure

**Right side of the boiler:**

- Primary air flap
- Cleaning closure
- Sink for electric heater at bottom of boiler

**Top side of the boiler:**

- Filling door
- Cleaning door cover
- Cleaning door
- Protection plate under the cleaning door

## 5. LIST OF SPARE PARTS

The complete disintegration of all H4xx-D series boilers can be found below. Use this list to identify the parts of the boiler when ordering or replacing them.

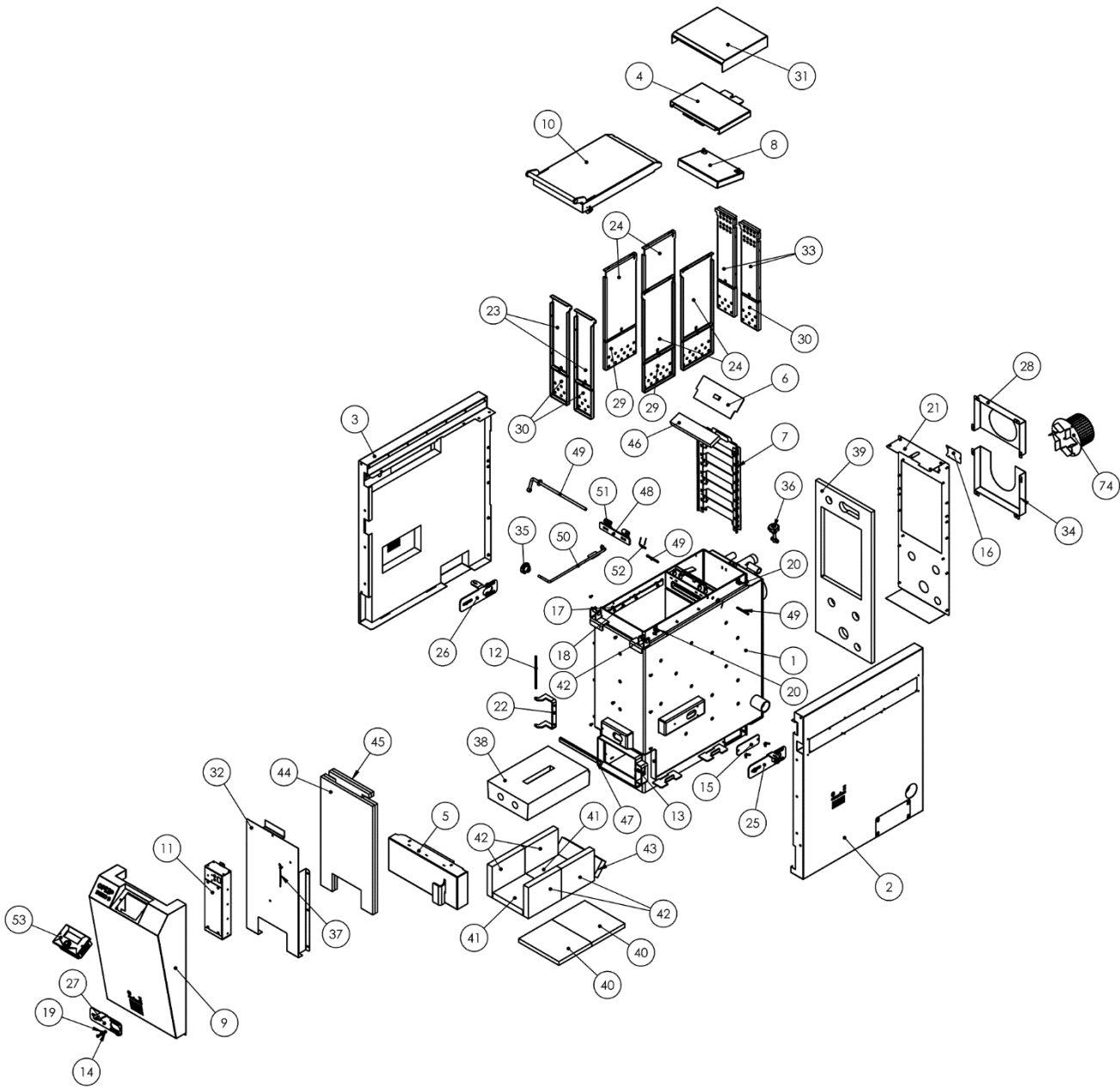

Item no.	Part no.	Part name	Amount
1	573369	Boiler weldment H416 EKO D	1
2	7001728	Right side cover assembly	1
3	7001729	Left side cover assembly	1
4	7001731	Cleaning doors assembly	1
5	7001734	Ash doors assembly	1
6	7001735	Filling chambre flap	1
7	7001770	Turbulator set	1
8	7001793	Heat exchanger insulation assembly	1
9	7001875	Front cover assembly	1
10	7001876	Assembly of the filling door	1
11	7001889	Electronics Box H4EKO D	1
12	214366	Peg	1
13	295616	Peg H4 Eko	1
14	295864	Spacer	9
15	3632502	Caps for cleaning holes	2
16	3632503	Cover	1
17	3632561	Spacer	6
18	3632562	Hinge belt II	2
19	3632629	Spacer 6,4	9
20	3651040	Upper clip	4
21	3653726	Back cover	1
22	3653813	Hinge of the ashtray door	1
23	3653829	Filling shaft cover I	2
24	3653830	Filling shaft cover II	4
25	3653839	Mobile Sheet	1
27	3653840	Mobile Sheet I	1
28	3653846	Exhaust fan box	1
29	3653850	Subdividing plate with air vents	4
30	3653851	Subdividing plate with air vents	4
31	3653912	Cover plate of the cleaning door	1
32	3653933	Sheet for holding the electronics	1
33	3653945	Filling shaft cover III	2
34	3653946	Exhaust fan box II	1
35	K0154.510	Handwheel, nut (VCT.50 B-M8-C2)	1
36	K0053.10075_49	Set of closing mechanism for cleaning doors	1
37	PT-303	Cabling tape	1
38	374224	Nozzle	1
39	577715	Rear insulation	1
40	577701	Bottom insulation	2
41	577776	Bottom schamott	2
42	577731	Side schamott	4
43	577740	Heat exchanger schamott	1
44	577766	Insulation front	2
45	577771	Izobrex for filling door	2
46	577772	Isolation inside	1
47	-	Isolation of the filling door 20x10 (l = 256mm)	1
48	7001903	Movable flap assembly	1
49	7001904	Lever of the flap-S	1
50	7001905	Flap bar	1
51	7001906	Rotary handle assembly	2
52	čep	B-6x35 ISO 2340	2
53	Control unit	OPOP H4-D	1



## 7. BOILER ASSEMBLY

A solid fuel boiler may only be installed by a company with a valid authorization to install it or by a person authorized by us. The list is available at [opop.cz](http://opop.cz) or you can request it at the telephone number 571 675 589. The project must be prepared according to the valid regulations.

### Boiler placement

The boiler must be installed in a separate boiler room, specially designed for heating. The boiler room must have sufficient space for installation and maintenance of the boiler. Sufficient circulation of fresh air for combustion must be ensured, the design of the chimney must ensure adequate draft for the type of boiler and must be in accordance with the installation criteria set forth in this manual and in the binding regulations. Never install the boiler in open spaces or balconies in areas occupied by people such as kitchen, living room, bathroom, bedroom, in areas where explosive and flammable materials are present.

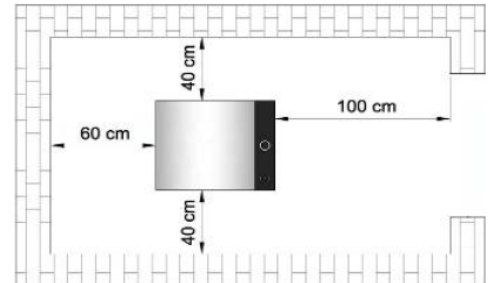

Install the boiler on a concrete base made of flame retardant material or on a fireproof substrate.

A minimum of free space should be around the boiler. During installation and during operation of the boiler, a safe distance of 200 mm from the flammable masses of the degree of flammability B, C1 and C2 (according to ČSN 06 1008) must be observed.

For lightly flammable substances of degree of flammability C3, which quickly burns and burns themselves after removal of the ignition source (eg paperboard, cardboard, bitumen and tarpaperboard, wood and fiberboard, plastics, floor coverings), the safety distance doubles, to 400 mm.

The safe distance must also be doubled if the degree of flammability of the building material is not proven.

### Installation of heating system pipes

In the rear part of the boiler is welded water inlet and outlet with diameter G1 1/4 ". These pipes can also be fitted with old type flanges if you change our old boiler to a new one and you do not want to change the pipes to connect to the boiler. Then the boiler fits its dimensions to the heating circuit to which our older type of H4v or H4eko boiler has been connected. Please inform us or your local retailer about the possibility of buying these flanges if you change the boiler from one of the older ones.

The heating system must be designed according to ČSN 06 0310: 2006 (Central heating, design and installation), ČSN 06 0830: 2006 (Safety devices for central heating and domestic hot water), ČSN 07 7401 (Water and steam for thermal energy devices with working steam pressure up to 8 MPa, EN 303-5 (Central heating boilers - Part 5: Solid fuel boiler with manual or automatic fuel supply, rated at maximum 300 kW).



The boiler must be installed in combination with the buffer tank.

### Installation of the drain valve

At the bottom of the boiler, a 1/2 " nozzle is welded to the boiler, into which the drain valve is screwed. After filling the water into the system, it is necessary to close the valve!

### Connection to the chimney

The boiler may only be installed to the chimney according to ČSN 73 4201: 2002. The connection of the hot water boiler must only be carried out with the approval of the chimney. The boiler must be connected to a separate chimney flue which has sufficient draft for virtually all possible operating conditions.



The draft of the chimney is always lower at the time of increasing humidity, mist and the heated head of the chimney on which the hot sun has been lit for a long time.

The flue path piping must be properly mounted and sealed of the boiler must be firmly assembled and fitted to prevent accidental or spontaneous release. We recommend that the flue pipe from the boiler to the chimney is no longer than 1m and that it rises towards the chimney; Recommended slope of at least 5% (3°). The connection is recommended to be direct - no more than one bend.

The boiler and the flue must comply with the fire regulations ČSN 06 1008: 1997 (Fire Safety of Thermal Installations), ČSN EN 13501-1: 2007 (Fire Classification of Building Products and Structures - Part 1: Classification according to the results of the reaction to fire tests) and may be installed at a safe distance of 400 mm from combustible materials. The safe distance must also be observed when the degree of flammability of a flammable substance is not proven.

## 8. CONNECTION OF THE COOLING LOOP

The H4xx EKO-D boiler is in accordance with the requirements of ČSN EN 303-5: 2013 and Government Decree 26/2003 Coll. equipped with a cold water exchanger to remove excess heat, which must ensure that the maximum water temperature in the boiler, ie 110 ° C, is not exceeded. This heat exchanger is designed as a flow-through water heater, which is controlled by a relief drain valve at the inlet. This valve can be ordered from us at any time so that installation on the cooling loop is as simple as possible.

### Principle of function

Insert the sensor of the safety valve into the sink in the side upper part of the boiler. The sensor reads the boiler water temperature. If the boiler water temperature increases to 95°C, the boiler automatically opens and discharges water into the built-in heat exchanger, which removes heat and prevents overheating of the boiler. After the boiler has cooled down, the valve automatically closes until it stops the cold water inlet to the exchanger. This activity can be repeated several times, depending on the amount of fuel in the hopper, respectively to the duration of reduced heat consumption through the heating system.

- The drain relief valve must always be connected to the water inlet to the cooling loop so that the cooling loop is not under constant water pressure.
- If the recommended cooling loop connection to the boiler is not adhered to in accordance with the operating instructions, the cooling loop may overpressure and consequently cause leakage.
- For proper operation of the valve, it must be ensured that the valve is connected to a permanent cooling water source of min. 2 bar. (preferably a public water supply) at a temperature of about 15 ° C
- Check the correct valve function at least once a year

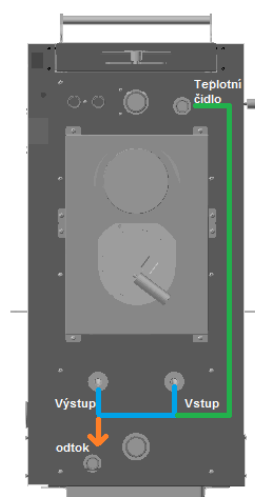

## 9. ELECTRIC HEATER INSTALLATION

The boiler is equipped with a sink for the electric heater on the right side. This can be used in combination with a thermostat so that the electric heater switches to the specified temperature. If the temperature is reached, the electric heater turns off. This is a secondary heating source. The electro spiral fitting has a G6/4" internal thread diaphragm and comes with a Regulus 3kW, 1F electro spiral with control and HDO. For connection, use the spacer as the electro spiral is 2 cm longer than the boiler width.

This electro spiral is already installed at the factory with a thermostat on which the desired temperature is set. The power cord may only be connected by a trained electrician with a valid authorization. For detailed installation information, refer to the operating instructions for this electro spiral.

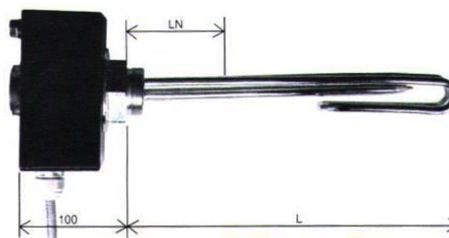

výkon [kW]	elektrické připojení	typové číslo	kód	materiál	LN-netopící konec [mm]	L-délka topného tělesa [mm]	min. velikost zásobníku	min. velikost nádrže
230 V	2	1/N/PE AC 230V	ETT-D-2.0	11783	niklovaná měď	100	RGC 120H	PS 200 HSK 500
	3	1/N/PE AC 230V	ETT-D-3.0	11784	niklovaná měď	100		

10. ELECTRIC SCHEME

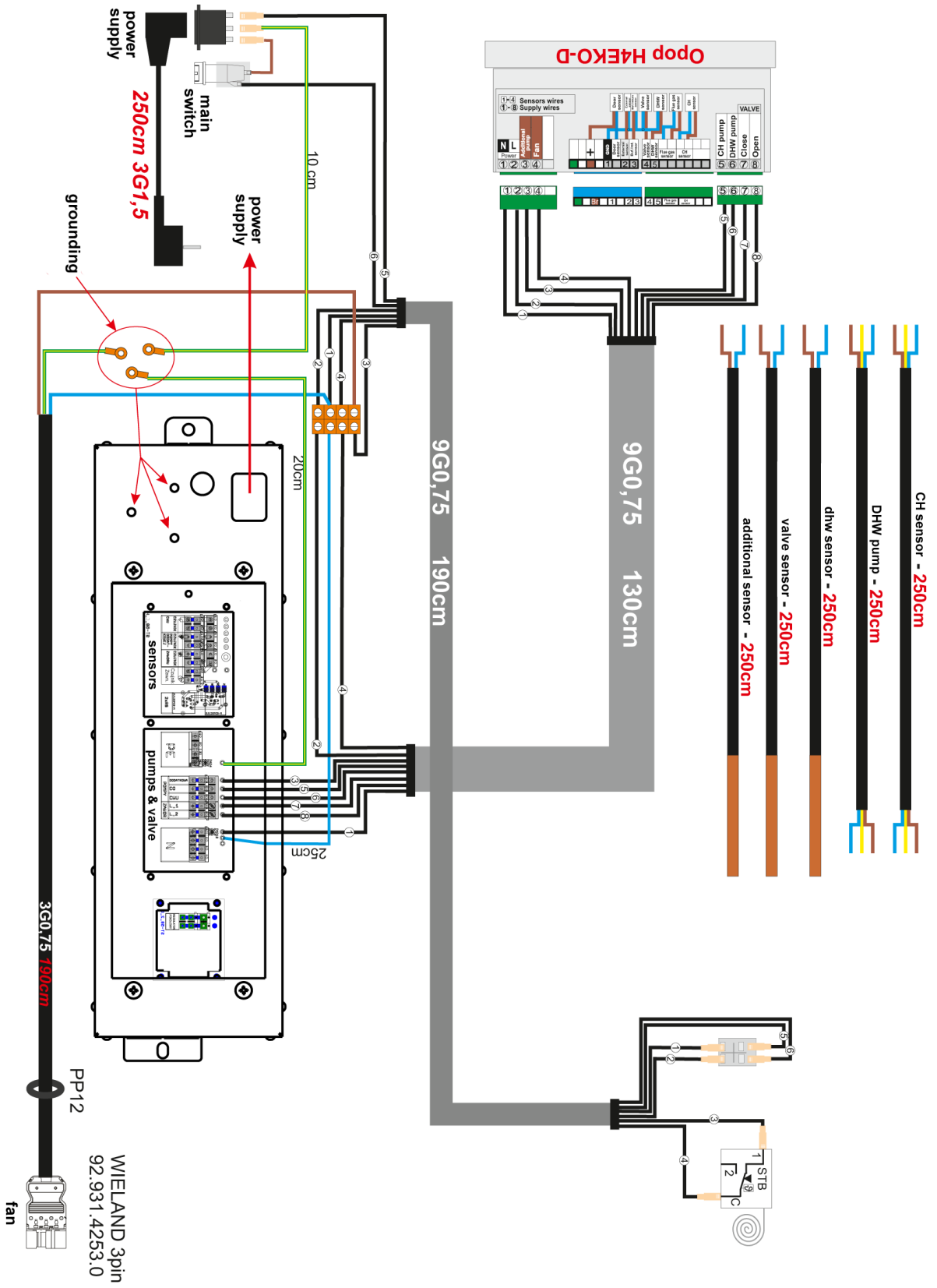

## 11. HYDRAULIC SCHEME

### CONNECTION WITH 1 HEATING CIRCUIT, MIXING VALVE, BUFFER TANK

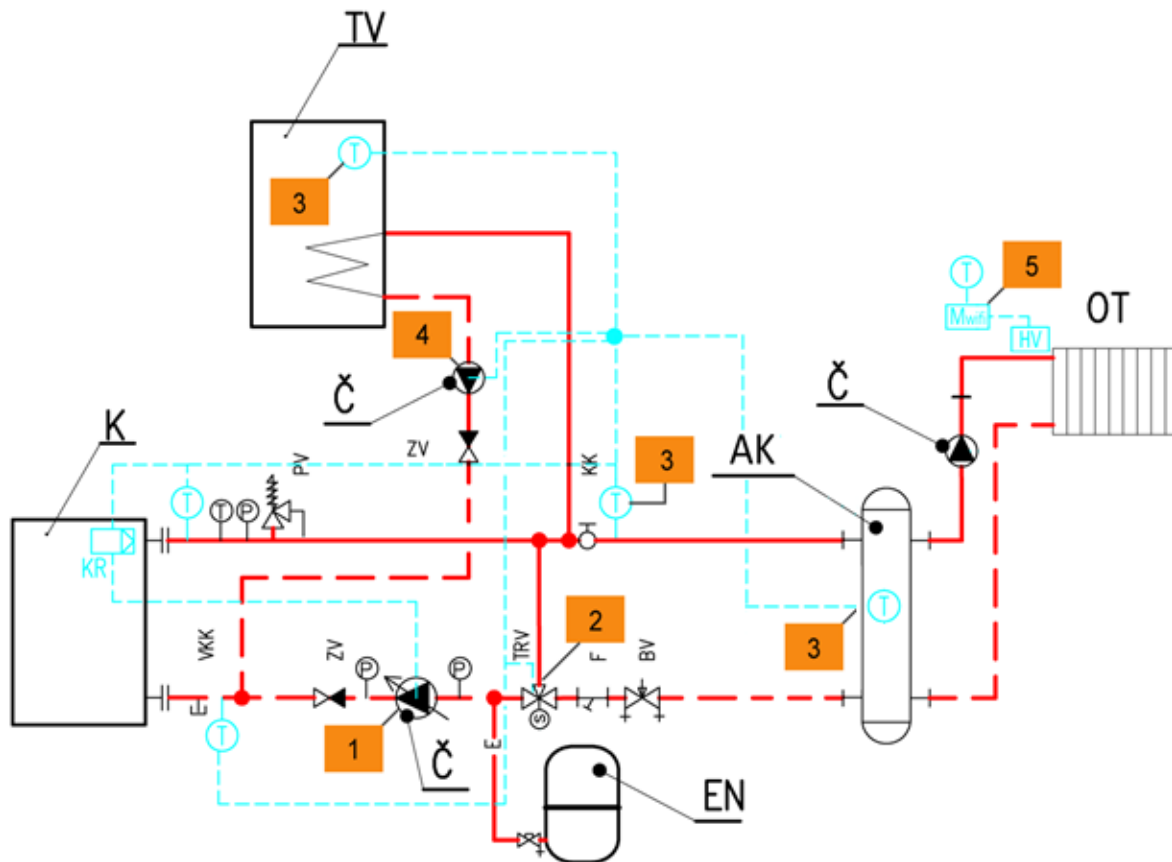

No.	Part	Type / Component / Description	El.connect.	Order number
1.	CH pump	Primary circuit pump	CH pump	-
2.	Mixing valve 1	3- or 4-way mixing valve (plugged into the 431N module)	Valve	-
3.	Temp.sensors KTY	KTY mixing valve sensor 1	Vlave sens.	345718000020
		KTY DHW sensor	DHW sens.	
		KTY buffer sensor	Buffer sens.	
4.	DHW pump	Domestic hot water pump	DHW pump	-
5.	Radiator valves control	Module wifi8 (for 1 objekt)	-	358120400020
		Zone sensor wifi8 (for 1 zone / room), (1 module = max. 8 zones / room)	-	358120400040
		Wifi8 valve head (for 1 radiator), (1 zone = max. 6 heads)	-	358120400030

CONNECTION WITH 1 HEATING CIRCUIT, MIXING AND THERMOSTATIC VALVE, BUFFER TANK

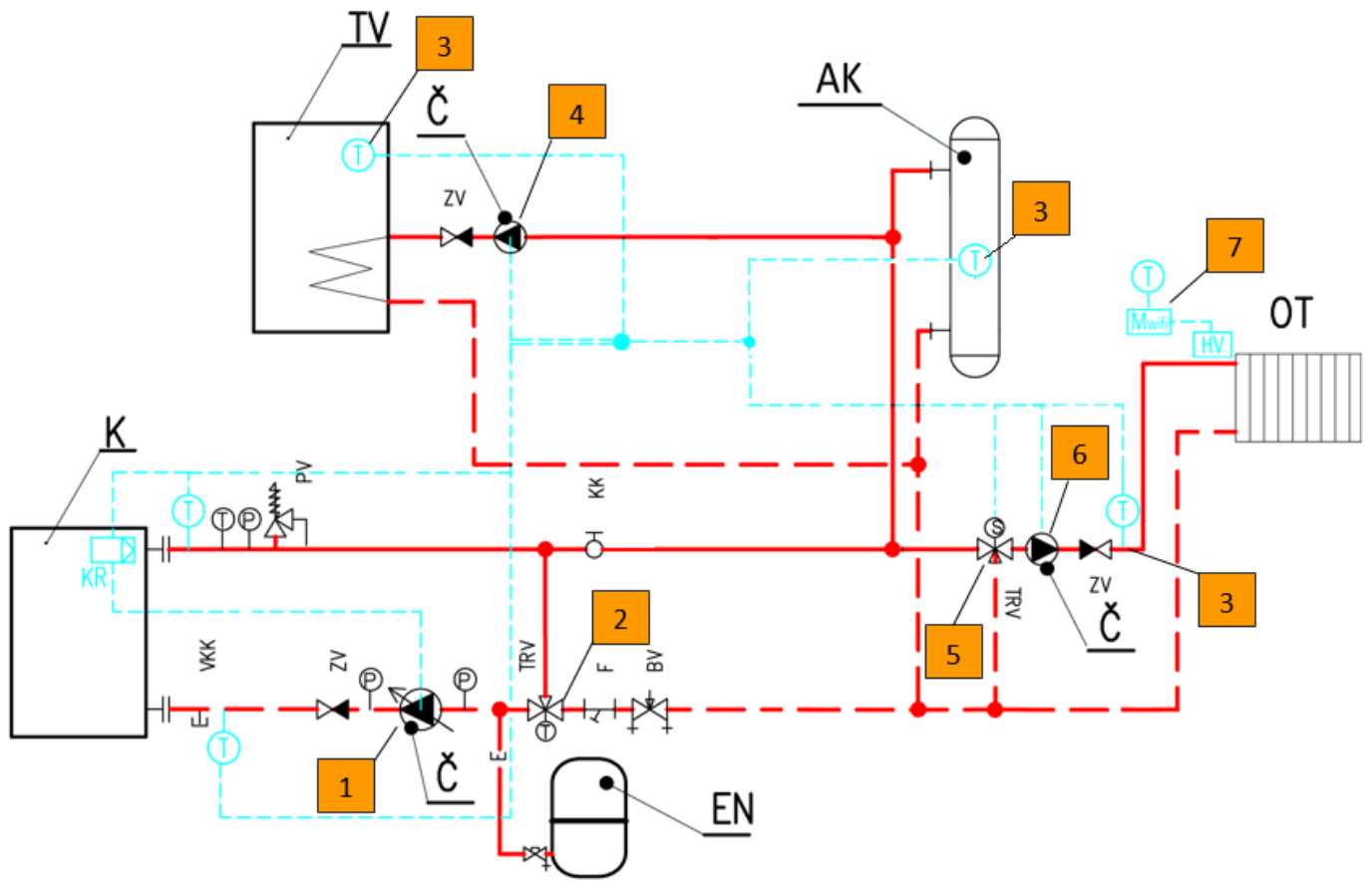

No.	Part	Type / Component / Description	El.connect.	Order number
1.	CH pump	Primary circuit pump	CH pump	-
2.	Thermostatic valve	3 – way thermostatic valve	-	-
3.	Temp.sensors KTY	KTY mixing valve 1 sensor	Vlave 1 sens.	345718000020
		KTY domestic hot water sensor	DHW sens.	
		KTY buffer sensors	Buffer sens.	
4.	DHW pump	Domestic hot water pump	DHW pump	-
5.	Mixing valve 1	3- or 4-way mixing valve (plugged into the 431N module)	Valve	-
6.	Mixing valve pump 1	Pump	Valve pump	-
7.	Radiator valves control	Module wifi8 (for 1 objekt)	-	358120400020
		Zone sensor wifi8 (for 1 zone / room), (1 module = max. 8 zones / room)	-	358120400040
		Wifi8 valve head (for 1 radiator), (1 zone = max. 6 heads)	-	358120400030

## 12. CONTROL UNIT



1. House heating – indicator of heating type. It can be divided into the following types:
  - a. House heating - only the central heating pump (CH) is active.
  - b. DHW priority - the DHW pump is activated as a priority, after the set DHW temperature has been reached, the DHW pump is deactivated and the DHW pump is activated to ensure the circulation of water in the primary circuit.
  - c. Parallel - DHW and CH pumps work simultaneously. Once the set DHW temperature has been reached, the DHW pump is deactivated and the DHW pump is still working to ensure the circulation of water in the primary circuit.
  - d. Summer Mode - Only the DHW pump is active.
2. Current date, room thermostat indication, flue gas temperature.
3. The entered and actual temperature of the central heating measured at the back of the boiler on the boiler outlet water pipe.
4. Indication of current fan speed.
5. Boiler status
6. Indication of the operation of the CH pump
7. DHW pump operation indication
8. Indication of the operation of the auxiliary pump
9. Indication of activation of the master mixing valve
10. Indication of the opening of the mixing valve when connected and activated.
11. Navigation key for entry and navigation in the menu.
12. Exit the menu, cancel the selection.

## 13. BASIC DUNCTION OF THE CONTROL UNIT

The control unit controls the water circulation pump (CH), the domestic hot water pump (DHW), the secondary circuit circulation pump, the mixing valve, the buffer tank and the exhaust fan.

It is also possible to control two additional mixing valves using 431N modules. With this type of controller, the fan speed is determined by measuring the boiler temperature and the flue gas temperature measured at the boiler outlet. The fan operates continuously and its speed depends directly on the actual boiler temperature, flue gas temperature and the difference of these parameters to the specified set temperature.

### 1. Main page

During the normal operation of the controller, the main page is displayed. Depending on the current operating mode, different pages are displayed. Pressing the impulse controller moves the user to the first level of the menu. The first four options in this menu will appear on the display.

We will display the next options by rotating the impulse controller. To select a function, press the impulse controller. Similarly, we proceed with changing the parameters. To make a change, you need to confirm it. This is achieved by pressing the impulse controller at the word CONFIRM.

If the user does not make any changes to the function, presses CANCEL. To exit the menu, use the EXIT button. **WARNING:** Standby does not turn off the power supply of the controller.

### 2. Firing up / Damping

With this function, the user can easily ignite / extinguish the fuel. After the initial loading and ignition of the fuel, select the Ignition function, which automatically controls the fan. After the optimal parameters of the central heating and flue gas temperature have been reached, the boiler goes into the operating mode continuously. After the boiler has switched to operating mode, the display will show instead of the Information *Ignition*, information *Work*.

From now on, this choice switches the fan on / off. With this function, we can turn the fan on / off at any time.

### 3. Screen view

With this feature, the user can select one of four control panel operation views:

- CH screen (displays the current operating mode of the boiler),
- Build in valve (displays the main valve parameters),
- Valve 1 (displays the parameters of the additional valve operation 1),
- Valve 2 (displays the parameters of the additional valve operation 2).



In order for the valve parameters panels to be active, these valves must be installed and configured correctly by the specialist.

### 4. Temperature settings

Here you can select the desired CH temperature from the "CH set temperature" submenu and the required "DHW set temperature" if the DHW heating is activated in the "Working modes" menu.

#### 4.1 CH set temperature

This option allows you to set the boiler temperature. The boiler temperature can vary from 45 °C to 85 °C. The entered CH temperature can also be changed directly in the main page of the controller by rotating the impulse controller.

#### 4.2 DHW set temperature

This option allows you to set the specified domestic hot water temperature. User can change this temperature from 30 °C to 60 °C.

## 5. Manual mode

For user convenience, the controller is equipped with Manual mode. In this function, each operating device (fan, CH pump, DHW pump, additional pump, valve) is switched on and off independently of each other and each active mixing valve can be closed, opened or stopped in the given position.

Pressing the impulse controller will start the function of the selected device. The device will be operated by pressing the impulse button. In addition, in the Fan output option the user has the option to set any fan speed.

## 6. Working modes, Pump modes

In this function, one of the four operating modes of the CH and DHW pump is activated according to the needs of the user.

- **House heating** - In this option, the controller enters the House heating mode. The CH pump will start operating above the pump switching temperature (factory set to 38 °C). Below this temperature (minus hysteresis 2 °C), the pump stops working.
- **Boiler (DHW) priority** - In this mode, the DHW pump (DHW) is first turned on and operates until the set DHW temperature has been reached. Once it is reached, the DHW pump is switched off and the CH pump is activated. The CH pump runs all the time until the temperature of the DHW tank drops below the set temperature by the DHW hysteresis value. Then the CH pump switches off and the DHW pump switches on (the pumps work alternately).

In this mode, the fan operation is limited by maximal DHW tank temperature to 62 °C to prevent overheating of the DHW tank.

- **Parallel pumps**  
In this mode, both pumps start operating simultaneously when the pump switch on temperature is reached. This temperature can be different for each pump, depending on the setting by the user. This means that one pump can be switched on before the other, but when the two set temperature limits are exceeded, the pumps will work simultaneously. The CH pump is operating continuously and the DHW pump switches off after the specified DHW temperature has been reached; on the other hand, it will be switched on when the temperature falls below the setpoint set by the set DHW hysteresis value.
- **Summer mode**  
In this option, the CH pump is switched off and the DHW pump switches on when the DHW set temperature is reached. It will operate continuously until the temperature drops lower by the DHW hysteresis value or if this condition is met:  $(\text{boiler temperature}) + 2\text{ °C} \leq (\text{DHW temperature})$ .  
In the summer mode, only the set boiler temperature is set, which is also the specified DHW temperature.

## 7. Time settings

Select the current time so that the functions that work with the current time work correctly.

## 8. Date settings

Select the current date so that the functions that work with the current date work correctly.

## 9. Fitters menu

All accessories that are connected to the boiler are activated and adjusted here. For a description of the Fitters menu, refer to the next chapter of this manual.

## 10. Language version

Use this function to select the language version of the controller.

## 11. Factory settings

It is possible to return to the factory setting values. By selecting the factory setting, the boiler settings set by the user are deleted.



## 14. FITTERS MENU

### 1. Valves settings, Build in valve

Activating and setting the mixing valve. The supply voltage of the valve is 230V. Connection to the "Valve" output of the boiler control unit.

**2. Valve settings, Valve 1, 2** - This function allows you to select settings for the operation of the additional mixing valve. In order for the valve to work properly and in accordance with the user's requirements, it is necessary to make it by setting the relevant parameters, its configuration (similar to the main valve). The detailed setting of the additional valves is provided in the 431N module manual, which allows the control of these additional valves.

**3. Room regulator temperature lower** – If the room thermostat is activated, this item can be adjusted so the boiler setpoint temperature should be set to reduce the boiler output, or deactivate the fan to achieve this reduced temperature.

**4. GSM module** - The GSM module is an additional device that works with the boiler controller to allow remote control of the boiler's operation by means of a mobile phone. The user is alerted by the SMS message to the possible alarm of the boiler controller and by sending the corresponding SMS is informed about the current temperature of all sensors. Once the authorization code is entered, it is also possible to remotely change the entered temperature.

Refer to the GSM module instructions for details.

**5. Internet module** - Use of this operating mode is possible only after purchase and connection of the S-500 additional control module, which is not part of the standard equipment of the controller. An Internet module is a device that allows you to remotely control the boiler's operation over the internet or the local network. The user checks the status of all boiler installed components on the computer or phone.

Refer to the Internet module instructions for details.

**6. Room regulator** - With this function, the user can select the appropriate room controller type. Selects between standard controller (traditional open-close position) and OPOP / TECH controller (RT10).

When the OPOP / TECH controller is connected, the user has the possibility to control and change the specified CH, DHW and mixing valve temperatures. All boiler controller alarms are also displayed. When working with the mixing valve, the user has a preview of the current outdoor temperature on the display panel with valve parameters.

**CAUTION:** No external voltage must be connected to the room controller outputs. Otherwise, the controller may be destroyed.

- *Control of CH pump* - after the room controller signals the boiler, the CH pump is switched off.
- *Control of the furnace* - after the room controller indicates the heating temperature is reached, the CH temperature drops to the set temperature.

**7. Operation algorithm** – enable or disable PID mode. In PID mode, the boiler unit modulates the fan speed. The closer the temperature is to the set temperature, the lower the speed of the fan. If the PID mode is deactivated, the fan turns only at fixed speed without modulation. Once the CH temperature is reached, the fan is deactivated.

**8. Buffer parameters** – the heating of the buffer tank is carried out using a temperature sensor inserted into the buffer tank. If the buffer tank heating is activated, the corresponding temperature sensor must also be connected, otherwise an alarm message will occur.

- a. *Set temperature* – enter the desired temperature in the buffer tank measured by the temperature sensor.
- b. *DHW function* – if the hot water tank is connected to the system and this is controlled by the DHW pump connected to the boiler unit, you can choose whether to use this DHW heating in the case of a heated buffer tank. Depending on the hydraulic connection, we recommend consulting with the installer.

**9. Pumps switch on temperature** - Tato volba slouží pro nastavení teploty zapnutí čerpadla ÚT (je to teplota měřená na výstupu vody z kotle) a čerpadla TUV Nad touto teplotou začíná čerpadlo pracovat. Vypnutí čerpadla nastane po poklesu teploty kotle pod teplotu zapnutí (mínus hystereze 2°C).

**10. DHW hysteresis** - This option is used to set the hysteresis of the specified boiler temperature. It is the maximum difference between the specified temperature (ie the selected boiler temperature at which the pump will shut down) and the temperature at which it will start working again.

*Example:*

The set temperature is 55 °C and the hysteresis is 5 °C.

After reaching the set temperature of 55 °C, the DHW pump switches off and the CH pump is switched on.

When the temperature drops to 50 °C, the DHW pump switches on again.

- 11. Additional pump** - The user has the option of connecting an auxiliary pump: circulator or valve pump. Depending on the pump selection, the settings need to be configured correctly.  
The user here sets the daily cycle and pump breaks for 30 minutes. To facilitate setting of these parameters, there is a possibility to copy the selected time interval to other days. Once the operating plan has been established, it is necessary to set the working time and pump shutdown time during the activity in the previously selected time interval. If necessary, it is also possible to quickly erase the current settings, thus making it easier to set new time intervals.
- 12. Encoder sensitivity** - With this setting, we can determine the sensitivity of the pulse converter button, (where 1 means the highest sensitivity).
- 13. External sensor calibration** - Correction of the outdoor sensor is performed during installation or after a longer operating time of the controller if the displayed temperature differs from the actual temperature. Control range: -10 to +10 ° C.
- 14. Boiler (DHW) disinfection** - Thermal disinfection involves raising the temperature to the required disinfection temperature, ie at least 60 °C throughout the DHW circulation. The purpose of DHW disinfection is the destruction of Legionella pneumophila, which causes a weakening of the immunity of the organism.  
After switching on this function (only in boiler priority mode), the boiler will heat until the disinfection temperature specified by the user has been reached. The disinfection time parameter specifies the duration of the disinfection (eg: 10 minutes).  
  
After that, the boiler returns to normal working mode. Once the disinfection is switched on, the disinfection temperature must be reached until the disinfection time is reached. Otherwise, the function is automatically deactivated.
- 15. Factory settings** – Reset of installation menu settings to factory settings.
- 16. PID sustain** – if the set temperature is reached, the boiler goes into the so-called sustain mode. In this mode, the fan is deactivated in order to prevent power increase. Caution: The boiler must be installed with a buffer tank so as not to overheat the water in the heating system and the boiler.
- 17. Display contrast** – change the font saturation on the display of the boiler control unit.

## 14. BASIC SETUP OF THE CONTROL UNIT

When commissioning the boiler, it is necessary to select the correct boiler output. The power is set by the technician who is installing the boiler in the control Unit's Service Menu. Ensure that the boiler output is set correctly so that the fan speed matches your boiler output.

The maximum boiler temperature can be set by pressing the navigation key and selecting the "CH temperature". This temperature will be maintained by the boiler and the ventilator will be deactivated after the CH temperature is reached.



Boiler performance affects external factors such as chimney draft, primary and secondary flaps, fan speed, fuel type, correct or incorrect power output calculated by the designer. Therefore, it is possible to exceed the set temperature of the CH. For this reason, it is necessary to install it with a buffer tank.

The maximum DHW temperature, if DHW heating is activated, can be set by pressing the navigation key in the item "DHW temperature". You activate the DHW heating in the "Pump operating modes" setting. If you activate DHW heating, make sure that the DHW sensor is connected in advance, otherwise an alarm message will occur.

## 15. IGNITING

The wood in the boiler burns out through the refractory nozzle. Place small pieces of wood and chips on the nozzle so that the nozzle is permeable and the flame can pass through the nozzle. Use a paper or a solid ignitor for ignition. In the Menu, touch "Ignition", and the fan will be activated. The ideal fan speed for heating is in the range of 20 to 40%. Higher fan speed may cause the flame to blow out. But these values are set from the factory in the Service menu.

It is now necessary to wait for the wood to start to burn and then close the door. The boiler will automatically enter the "Operation" mode after reaching the chimney temperature above 45 °C. When this happens, boiler goes to "Operation". The boiler will now work to achieve the set CH temperature by modulating the fan speed.

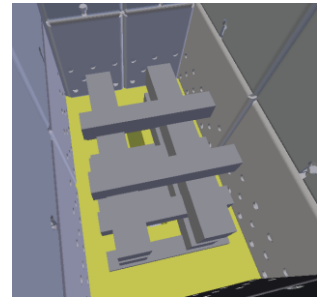

*Proper placement of wood for ignition*

## 16. WORK

In operation, the boiler is controlled according to the CH temperature you set and also the flue gas temperature. If the flue gas temperature drops below 45 °C, a refueling necessary to keep flame inside the boiler.

The fan operates until the set CH temperature is reached. Then, the fan will be deactivated. The boiler temperature may continue to rise, depending on the chimney draft and the opening of the primary air flaps.

The correct setting of the primary and secondary air flaps is indicated by a line above the flap rod. This setting ensures the required boiler output and ideal combustion emissions.

If you want the fuel in the boiler to withstand the flame longer, the primary air rod on the side of the boiler can be closed more. The flaps can never be closed to 100%, as the burning fuel always requires at least a minimum air supply for proper combustion.



During combustion, there is accumulation of fumes in the filling shaft. Therefore, never open the filling door during burning. Wait for the chimney temperature to drop below 45 °C, leaving only the hot layer that forms the smallest amount of smoke in the filling chamber. After that, then you can put more fuel inside.

The primary air rod on the side of the boiler influences the boiler output. The figure shows the setting to achieve the desired boiler output. By closing, you reduce the boiler output and extend the burning time. The position of the flaps must be identical on both sides, otherwise the wood in the filling chamber will burn unevenly.

O – open flap position      Z – close flap position (still allows the air to enter the boiler)

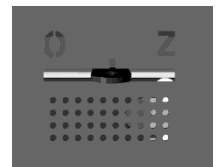

The secondary air rod is located in the front of the boiler. It fumes the combustion air directly into the nozzle and improves the quality of combustion of fuel and gases. The ideal position of the flap is indicated by a line above the flap rod. During burning, there is no need to interfere with the flap position. In general, if you close the primary flaps, you can move the secondary flap at the same rate so that the combustion quality is as good as possible. While still in the closed position, the flap still allows air to be drawn into the nozzle.

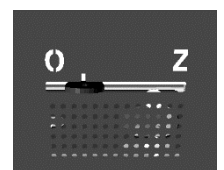

## 17. FUEL LOADING

Fuel is added to the boiler when only the hot layer of wood remains in the filling chamber, all the large pieces are burned. It happens according to the actual flue gas temperature, which is displayed at the top right of the display. The standard combustion temperature is above 100 °C. If the flue gas temperature drops below about 50 °C, only the hot layer remains in the boiler and the boiler is ready to load new fuel inside.

Before opening the filling door, move the suction flap to the open position and wait for 20 seconds. Opening the flap ensures that the residual smoke is drawn directly into the chimney. After that, the door can be opened, see if all the smoke is sucked out and then open the door slowly.

Load new logs onto the hot layer. Use gloves because the hot layer is really hot. After loading the wood, close the door and remember to move the suction flap to the closed position.





Never leave the suction flap in the open position during the boiler operation. Otherwise, the fuel in the filling shaft will burn upwards, not through the nozzle. This may cause damage to the metal parts in the filling shaft or damage to the suction flap. Not to mention that all of your heat would have fled to the chimney before it was given to the water.



## 18. EXTINCTION

The boiler is extinguished when the flue gas temperature drops below 45 °C and the user does not add more fuel. The fan stays in the deactivated position, on the display is the Extinction sign shown.

The boiler can be extinguished at any time manually by entering "Extinction" in the menu. This will deactivate the fan, but be careful if there is still fuel in the filling shaft, this will still burn according to the natural chimney draft. Similarly, combustion products will still accumulate in the boiler. Therefore, even after extinguishing when opening the door, follow the instructions in the Fuel loading section. If you open the filling door swiftly without an open suction flap, the smoke will escape into the room.

## 19. MAINTENANCE

The boiler must be cleaned regularly. And not only the filling shaft and combustion chamber, but also the heat exchanger. Follow the instructions below to keep your boiler in the best possible condition.

1. Filling shaft: open the filling door and move the residual ash through the nozzle to fall down into the combustion chamber or vacuum it out by vacuum cleaner for hot ash. Clean the side shield plates in the filling shaft with a scraper if necessary.
2. Combustion chamber: Open the bottom door and clean all the ash out of the combustion chamber. Check the correct position of all chamotte bricks before closing to avoid bad air flow from the combustion chamber to the boiler exchanger.
3. Heat exchanger: Remove the cleaning door at the top of the boiler. Below them you will find a shielding flap, which you also remove. Now you can clean the walls of the heat exchanger using a scraper and brush supplied with the boiler. The residual ash falls to the bottom of the exchanger under the heat exchanger. This ash can either be vacuumed with an ash cleaner with a longer extension so that you get under the heat exchanger, or if you do not have the ash cleaner, use cleaning openings on both sides of the boiler to remove residual ash from the bottom of the heat exchanger, see point 4.
4. Cleaning opening: There is a small cover at the underside of the boiler (left and right), which serves to remove ash that falls under the heat exchanger. Remove the cover sheet first on the side casing of the boiler, then unscrew the 2 pcs of wing nuts so that you can remove the metal plate. Using a cleaning tool, remove the ash out onto the shovel or use a vacuum cleaner.
5. Exhaust fan: Before the season, we recommend unscrewing the exhaust fan and removing the ash that has accumulated behind the fan in the spiral cabinet. Brush the fan flaps carefully to check that the fan propeller is not clogged. If it is not firmly attached, tighten the lock nut that holds the propeller on the fan shaft.

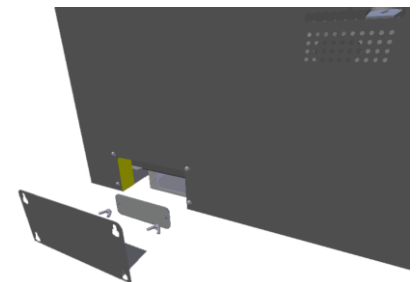

*Cleanina opening on the sides*



After cleaning, be sure to bring the boiler back to its original state. So close all the doors, screw the cleaning plate back in, tighten the fan in an airtight manner, and make sure all the components (chamottes, cover plates in the filling shaft, turbulators, cleaning flap) are in the right place.

## 20. SAFETY INSTRUCTIONS

Residual risks and their prevention. The risks arising from the operation of the boiler under conditions of foreseeable use and reasonably foreseeable misuse have been minimized by available technical means. Despite the constructional and technical measures implemented, certain residual risks resulting from the risk analysis that are given by the technological process during the different phases of the device's life remain in the boiler operation.

These include in particular the risks of inattentiveness of the boiler operator and failure to observe safety precautions during operation. To further reduce the risks and ensure greater security efficiency, we draw attention to the possible occurrence of certain residual risks that cannot be eliminated by any technical solution.

<b>Risks when supplying the boiler and its accessories</b>		
<b>Risk Source</b>	<b>Risk Management</b>	<b>Hazard Elimination</b>
Means of transport - a truck, a personal car of technician	Restrictions on the movement of workers (neighbors, family members) and machines at the place where the equipment will be unloaded from a car	Pre-define the unloading area and draw attention to this fact of the employee (neighbors, family members)
Handling truck, forklift truck, arm of the truck or other means by which the equipment will be moved	There is a risk of injury or damage being caused by parts of the devices that are being moved	Thoroughly consider the strategy of unloading and transporting individual parts of the product to the location where the product is temporarily stored or directly assembled
Storage of devices, whether in a assembled or disassembled state	collisions of persons, machines, vehicles, etc. with stored parts of the equipment. Condensation of water in the wiring and consequent injury of the technician, or damage to equipment	Mark the storage space appropriately. The area must be dry so that moisture does not get into the electrical installation
<b>Risks when placing the boiler at a designated location and completing it</b>		
<b>Risk Source</b>	<b>Risk Management</b>	<b>Hazard Elimination</b>
a forklift, or other means by which the equipment will be installed	There is a risk of injury or damage being caused by parts of the devices that are being moved	Take extra caution if your staff or you are to help our technicians
assembly itself	Injuries caused by a drill, angle grinder, and common tools that technicians will use. E.g. hammer, screwdriver, file, etc. The fall of some of the device components.	If your staff or you, help our technicians, have proper protective equipment. E.g. protective goggles, working gloves, etc. During the entire work, be extremely cautious
<b>Risks in normal boiler mode and its accessories</b>		
<b>Risk Source</b>	<b>Risk Management</b>	<b>Hazard Elimination</b>
Boiler body	Burning damage by hot door (stoking, cleaning, ashtray) when opened, hand or face burning at the moment of opening	Doors open only with protective gloves, the doors are in direct contact with flue gases and can reach temperatures up to 400°C. Open the door so that any spillage of hot flue gases does not hit any part of the body. The danger takes a few seconds before the pressure inside filling chambre equals.
Combustion chamber	Hand injuries, burning damage by the hot smoke. Removing ash from the combustion chamber.	Manipulate with fireclay only in protective gloves intended for this purpose and in the cold state of the fireclay. The ash may still be hot, so store ash only at the designated locations

<b>Risk during maintenance of the boiler and its accessories</b>		
<b>Risk Source</b>	<b>Risk Management</b>	<b>Hazard Elimination</b>
Combustion chamber	Burning, inhaling dust, eye contact with dust	If the boiler is not shut down for a long time, its parts may be still hot, therefore use protective gloves. When cleaning the combustion chamber, use goggles and respirator. The recommended downtime is 4 hours.
<b>Thermal risks</b>		
The boiler must not be exposed to higher working pressure than prescribed		
It is forbidden to overheat the boiler		
The boiler must be protected against low-temperature corrosion by appropriate connection with automatic return temperature valve		
Only the prescribed fuel can be burned in the boiler		
it is forbidden to store combustibles near the boiler		
<b>Risks associated with fuel handling</b>		
When handling the fuel, particulate matter is emitted. Therefore, the operator should use appropriate protective equipment according to the degree of dustiness		
Since this is a fuel, the relevant fire regulations must be followed and a suitable fire extinguisher		
<b>Ergonomic risks</b>		
the boiler must be in a horizontal position in the boiler room		
during operation of the boiler, all doors, lids and cover must be properly closed		

## 21. MEASURES IN CASE OF FAILURE

ALARM MESSAGE	INFO
Damaged flue gas sensor	It can not automatically ignite because the transition between igniting and operation is based on the flue gas temperature. You can ignite the boiler manually in Manual mode. Check for an adequate connection of the flue gas sensor, or, if the connection is OK, replace the sensor.
Damaged buffer sensor	The buffer tank sensor is a KTY type. Check the buffer tank sensor connection. Be careful to extend the cable of this sensor. The standard resistance at room temperature is 2Kohms. If you extend the sensor too much, the resistance characteristic and the alarm message change. If the resistor is well connected, replace the sensor.
Damaged CH sensor	The boiler output sensor is KTY type. Check its connection. If the wiring is correct, replace the sensor with a new one.
Damaged DHW sensor	The DHW sensor is KTY type. Check the DHW sensor connection. Be careful to extend the cable of this sensor. The standard resistance at room temperature is 2Kohms. If you extend the sensor too much, the resistance characteristic and the alarm message change. If the resistor is well connected, replace the sensor.
Damaged MOSFET sensor 1 Too high MOSFET temperature	The MOSFET transistor is the component responsible for changing the speed of the exhaust fan. The standard temperature on this component does not exceed 50 °C. If the temperature is too high, there will be an alarm message. Check the operation of the exhaust fan, remove it, clean it and try again. If the problem persists, call the OPOP service.
Damaged equithermal sensor Damaged outdoor sensor built-in valve	If you connect an outdoor temperature sensor, it is possible to control the mixing valve equithermally. So adjust the set temperature on the valve according to the outside temperature. Before activating this function, make sure that the outdoor sensor is properly connected. Otherwise, an alarm message will occur. Too long sensor cable can cause change of resistance characteristic and alarm message.
Damaged return sensor	The return sensor is KTY type. Check the return sensor connection. Be careful to extend the cable of this sensor. The standard resistance at room temperature is 2Kohms. If you extend the sensor too much, the resistance characteristic and the alarm message change. If the resistor is well connected, replace the sensor.
Damaged valve sensor	If you activate the mixing valve, make sure the valve sensor is connected. Otherwise, an alarm message will occur. Be careful to extend the cable of this sensor. The standard resistance at room temperature is 2Kohms. If you extend the sensor too much, the resistance characteristic and the alarm message change. If the resistor is well connected, replace the sensor.
Failed ignition	The maximum ignition phase time is 30 minutes. If the flue gas temperature does not exceed 80 °C or the temperature of the CH does not exceed 40 °C, an alarm message will occur.
Module not found	If the boiler is connected to the Internet via opop.emodul.eu, it may happen that the link to the router is not detected during registration. In this case, make sure that the Internet cable connection is OK, that you are registering according to the instruction manual. If problems persist, ask your ISP to unlock the communication port 2000 on your router, or call OPOP service.
The temperature does not rise Temperature does not increase	If the boiler is in operation for more than 30 minutes and the temperature of the boiler has not exceeded the minimum limit for that time, an alarm message will be issued. Make sure that the boiler is filled with water, that the CH sensor is properly positioned in the water sink on the back of the boiler. Alternatively, call the OPOP service.
Too high floor temperature	If you activate an additional pump, one of the functions of this pump is floor heating. Before activating the additional pump, first connect the sensor. The sensor is KTY type. Be careful to extend the cable of this sensor. The standard resistance at room temperature is 2Kohms. If you

	extend the sensor too much, the resistance characteristic and the alarm message change. If the resistor is well connected, replace the sensor.
Disconnected safety thermostat	If the room thermostat is activated but is not connected, this error state will be announced. Ensure that the thermostat is properly connected, that it is functional and connected to the power supply.
Incorrect fan Fan: Damaged bearings Fan: shaft obstruction	If a higher current consumption is generated on the fan, this error message may occur. Check the cleanliness of the fan and proper fan blades attachment. Rotating blades must not be deformed. Check the area of the spiral cabinet behind the exhaust fan, which must be clean without ash deposition. Also check fan operation, no noise must be heard. If the problems persist, call OPOP Service.
There is no communication with the Internet There is no communication with GSM There is no communication with the thermostat	If any of these accessories are activated but not physically connected, an error message will occur. Check for correct wiring and accessory settings. Alternatively, call the OPOP service.
Low fuel level	In the event of a flue gas temperature drop, information about the empty hopper is displayed. This happens when the flue gas temperature drops below 48 °C in Operation mode. At this time it is possible to add new fuel to the hot layer. If the temperature drops even more, below 35 °C, the Extinction will be announced and the boiler (fan) switches off.
Too high temp. valve 1	If the temperature on the mixing valve is above 85 °C, an alarm message will sound. Ensure that the boiler size is properly calculated to ensure that its output corresponds to the heat loss of the building. The boiler must be operated in accordance with the law with an accumulation tank to store excess heat.
Too high CH temperature	The maximum temperature of the central heating is controlled by two sensors, namely the CH sensor (KTY type) and the STB sensor (safety sensor). Both sensors are located at the back of the boiler. If the CH temperature exceeds 85 °C, the CH sensor will sound an alarm. If the temperature of the CH continues to rise, the fan power is deactivated by means of the STB safety sensor at a temperature above 90 °C. In this case, after cooling the boiler, it is necessary to press the button on the STB sensor at the back of the boiler so that the boiler is put back into operation. Make sure the system and the boiler are running water and that the boiler is installed according to the law with the buffer tank. Alternatively, call the OPOP service.

- From the point of view of safety and economy of operation, the appliance must be operated according to the instructions in this manual.
- The boiler may be left unattended, provided that the power is set so that it can not overheat the system (damped operation) or if it is equipped with a regulated and operable draft of the combustion air, however, it must be under the occasional inspection of the operator.



During operation, some parts of the boiler (doors, cleaner and ashtray door, smoke flue) can be heated to a higher temperature, causing burns when touched. Therefore, use the protective gloves.

- The boiler may only be operated by adults who are familiar with this manual. Keeping children unattended on the appliance is inadmissible.
- It is forbidden to use flammable liquids for heating in the appliance and in any way increase its rated output (thermal overload) during operation.
- The user may only carry out routine maintenance or replace spare parts. Do not interfere with the boiler construction, change its function, or leave the damaged product in operation.



Certainly during the first and subsequent heating intervals, excessive air condensation on the boiler surfaces may occur; in the ash section, a dark fluid may appear. This is due to the low water temperature in the boiler (below the condensing point of 65 °C) and the low flue gas temperature. The condensing will cease after partial burning of the combustion products on the walls and after melting above 65 °C. In any case, this is not a leakage of the boiler. Every boiler is thoroughly tested with overpressure and the possibility of leakage is virtually eliminated.

Air condensation occurs:

- at low draft of the chimney. If this is permanently low, it is removable only by a structural modification. If temporarily low, it is due to weather conditions
- with wet fuel
- when the low-temperature operation is permanently at a low temperature below the air condensing point of the flue gas, ie 65 °C
- Incorrect boiler size due to heat losses of heated space
- During ignition when chimney flap is not opened
- in case of improper handling.



When combustion of wet or damp fuel, nominal power may not be achieved, the boiler becomes excessively clogged. This results in considerable economic losses, which are reflected in increased fuel consumption and reduced boiler life.

There are several important principles that need to be observed to ensure that the boiler function is safe and economical.

- customer conscience
- adequate chimney draft operation
- clean boiler (drafts and vents)
- tight boiler - properly installed and sealed cleaning, stoking and ash door
- Correct boiler output selection for a given heated object
- Properly dried fuel

## 22. ENERGY EFFICIENCY

I.	II.	III.	IV.	V.	VI.
the name or trademark of the supplier;	supplier's model identifier;	energy efficiency class	nominal heat output in kW	Energy Efficiency Index	seasonal energy efficiency of heating in %
<b>OPOP s.r.o.</b>	<b>H416 EKO-D</b>	<b>A+</b>	<b>16</b>	<b>115</b>	<b>78</b>
<b>OPOP s.r.o.</b>	<b>H420 EKO-D</b>	<b>A+</b>	<b>20</b>	<b>115</b>	<b>78</b>
<b>OPOP s.r.o.</b>	<b>H425 EKO-D</b>	<b>A+</b>	<b>25</b>	<b>115</b>	<b>78</b>

## 23. IDENTIFICATION MARKS

model identification mark: <b>H416 EKO-D</b>							
Condensation boiler:	no	Solid-fuel cogeneration boiler:	no	Combined boiler:	no		
Fuel filling mode: automatic	Manual: the boiler should be operated with a DHW cylinder of at least x (*) liters / Automatic: it is recommended that the boiler be operated with a DHW cylinder of at least x (**) liters]						
Fuel		Preferred fuel (only one):		Other suitable fuel:			
Wood logs, moisture content $\leq 25\%$		yes		no			
Wood chips, moisture content 15-35%		no		no			
Wood chips, moisture content $> 35\%$		no		no			
Molded wood in the form of pellets or briquettes		no		no			
Sawdust, moisture content $\leq 50\%$		no		no			
Other wood biomass		no		no			
Non-wood biomass		no		no			
Black coal		no		no			
Brown coal (including briquettes)		no		no			
Coke		no		no			
Anthracite		no		no			
Briquettes made from a mixture of fossil fuels		no		no			
Other fossil fuels		no		no			
Briquettes from a mixture of biomass (30-70%) and fossil fuels		no		no			
Another mixture of biomass and fossil fuels		no		no			
<b>Features for Preferred Fuel:</b>							
Seasonal energy efficiency of indoor space heating $\eta_s$ [%]:			<b>78</b>				
Energy Efficiency Index EEI:			<b>115</b>				
Energy efficiency class:			<b>A+</b>				
Name	Designation	Value	Unit	Name	Designation	Value	Unit
<b>Useful heat output</b>				<b>Useful efficiency</b>			
At nominal heat output	$P_n^{(***)}$	<b>16,0</b>	kW	At nominal heat output	$\eta_n$	<b>81,3</b>	%
At [30%] rated thermal output, if applicable	$P_p$	Not used	kW	At [30%] rated thermal output, if applicable	$\eta_p$	Not used	%
<b>Solid fuel cogeneration boilers: Electrical efficiency</b>				<b>Consumption of auxiliary electric power</b>			
At nominal heat output	$\eta_{el,n}$		%	At nominal heat output	$e_{lmax}$	<b>0,11</b>	kW
				At [30%] rated thermal output, if applicable	$e_{lmin}$	Not used	kW
				Built-in secondary emission reduction device, if applicable		Not used	kW
				In standby mode	PSB	<b>0,002</b>	kW
Contact information		<b>OPOP s.r.o. , Zašovská 750, Valašské Meziříčí, 757 01</b>					
(*) Tank volume = $45 \times Pr \times (1 - 2,7 / Pr)$ or 300 liters, whichever is higher, Pr being expressed in kW							
(**) Tank volume = $20 \times Pr$ where Pr is expressed in kW							
(***) For preferred fuel, Pn equals Pr							

model identification mark: <b>H420 EKO-D</b>							
Condensation boiler:	no	Solid-fuel cogeneration boiler:	no	Combined boiler:	no		
Fuel filling mode: automatic	Manual: the boiler should be operated with a DHW cylinder of at least x (*) liters / Automatic: it is recommended that the boiler be operated with a DHW cylinder of at least x (**) liters]						
Fuel		Preferred fuel (only one):		Other suitable fuel:			
Wood logs, moisture content ≤ 25%		yes		no			
Wood chips, moisture content 15-35%		no		no			
Wood chips, moisture content > 35%		no		no			
Molded wood in the form of pellets or briquettes		no		no			
Sawdust, moisture content ≤ 50%		no		no			
Other wood biomass		no		no			
Non-wood biomass		no		no			
Black coal		no		no			
Brown coal (including briquettes)		no		no			
Coke		no		no			
Anthracite		no		no			
Briquettes made from a mixture of fossil fuels		no		no			
Other fossil fuels		no		no			
Briquettes from a mixture of biomass (30-70%) and fossil fuels		no		no			
Another mixture of biomass and fossil fuels		no		no			
<b>Features for Preferred Fuel:</b>							
Seasonal energy efficiency of indoor space heating $\eta_s$ [%]:			<b>78</b>				
Energy Efficiency Index EEI:			<b>115</b>				
Energy efficiency class:			<b>A+</b>				
Name	Designation	Value	Unit	Name	Designation	Value	Unit
<b>Useful heat output</b>				<b>Useful efficiency</b>			
At nominal heat output	$P_n^{(***)}$	<b>20,0</b>	kW	At nominal heat output	$\eta_n$	<b>81,5</b>	%
At [30%] rated thermal output, if applicable	$P_p$	Not used	kW	At [30%] rated thermal output, if applicable	$\eta_p$	Not used	%
<b>Solid fuel cogeneration boilers: Electrical efficiency</b>				<b>Consumption of auxiliary electric power</b>			
At nominal heat output	$\eta_{el,n}$		%	At nominal heat output	$e_{lmax}$	<b>0,22</b>	kW
				At [30%] rated thermal output, if applicable	$e_{lmin}$	Not used	kW
				Built-in secondary emission reduction device, if applicable		Not used	kW
				In standby mode	PSB	<b>0,002</b>	kW
Contact information		<b>OPOP s.r.o. , Zašovská 750, Valašské Meziříčí, 757 01</b>					
(*) Tank volume = $45 \times Pr \times (1 - 2,7 / Pr)$ or 300 liters, whichever is higher, Pr being expressed in kW							
(**) Tank volume = $20 \times Pr$ where Pr is expressed in kW							
(***) For preferred fuel, $P_n$ equals Pr							

model identification mark: <b>H425 EKO-D</b>							
Condensation boiler:	no	Solid-fuel cogeneration boiler:	no	Combined boiler:	no		
Fuel filling mode: automatic	Manual: the boiler should be operated with a DHW cylinder of at least x (*) liters / Automatic: it is recommended that the boiler be operated with a DHW cylinder of at least x (**) liters]						
Fuel		Preferred fuel (only one):		Other suitable fuel:			
Wood logs, moisture content $\leq 25\%$		yes		no			
Wood chips, moisture content 15-35%		no		no			
Wood chips, moisture content $> 35\%$		no		no			
Molded wood in the form of pellets or briquettes		no		no			
Sawdust, moisture content $\leq 50\%$		no		no			
Other wood biomass		no		no			
Non-wood biomass		no		no			
Black coal		no		no			
Brown coal (including briquettes)		no		no			
Coke		no		no			
Anthracite		no		no			
Briquettes made from a mixture of fossil fuels		no		no			
Other fossil fuels		no		no			
Briquettes from a mixture of biomass (30-70%) and fossil fuels		no		no			
Another mixture of biomass and fossil fuels		no		no			
<b>Features for Preferred Fuel:</b>							
Seasonal energy efficiency of indoor space heating $\eta_s$ [%]:				<b>78</b>			
Energy Efficiency Index EEI:				<b>115</b>			
Energy efficiency class:				<b>A+</b>			
Name	Designation	Value	Unit	Name	Designation	Value	Unit
<b>Useful heat output</b>				<b>Useful efficiency</b>			
At nominal heat output	$P_n^{(***)}$	<b>25,0</b>	kW	At nominal heat output	$\eta_n$	<b>81,5</b>	%
At [30%] rated thermal output, if applicable	$P_p$	Not used	kW	At [30%] rated thermal output, if applicable	$\eta_p$	Not used	%
<b>Solid fuel cogeneration boilers: Electrical efficiency</b>				<b>Consumption of auxiliary electric power</b>			
At nominal heat output	$\eta_{el,n}$		%	At nominal heat output	$e_{lmax}$	<b>0,22</b>	kW
				At [30%] rated thermal output, if applicable	$e_{lmin}$	Not used	kW
				Built-in secondary emission reduction device, if applicable		Not used	kW
				In standby mode	PSB	<b>0,002</b>	kW
Contact information		<b>OPOP s.r.o., Zašovská 750, Valašské Meziříčí, 757 01</b>					
(*) Tank volume = $45 \times Pr \times (1 - 2,7 / Pr)$ or 300 liters, whichever is higher, Pr being expressed in kW							
(**) Tank volume = $20 \times Pr$ where Pr is expressed in kW							
(***) For preferred fuel, $P_n$ equals Pr							

## 24. REGULATIONS AND STANDARDS

ČSN 06 0310 - Central Heating. Design and Assembly.

ČSN 06 0830 - Safety Devices for Central Heating and Service Water Heating

ČSN 06 1008 - Fire Safety of Local Appliances and Heat Sources (Water Heaters up to 50 kW)

ČSN 06 1610 - Flue Parts of Home Appliances

ČSN 07 0245 - How Water and Low Pressure Steam Boilers. Water Heaters up to 50 kW.

Technical requirements:

ČSN 07 7401 - Water and Steam for Thermal Energy Devices with Operating Excess Pressure up to 8Mpa

ČSN EN 13 501-1+A1 – Classification of construction products and structures

Part 1: Classification in accordance with the Fire Reaction Tests.

ČSN 73 0831 - Fire Safety of Constructions. Gathering Areas.

ČSN 73 4201 - Chimneys and Flues. Designing, Implementing and Connecting Fuel Appliances.

ČSN 73 4210 - Implementation of Chimneys and Flues and Connecting Fuel Appliances

ČSN EN 303-5 – Solid Fuel Boilers for Central Heating

163/2002 Coll. - Government Directive

26/2003 Coll. - Government Directive

185/2001 Coll. - Act on Waste

477/2001 Coll. - Act on Packaging

34/1996 Coll. - Act on Protecting Consumers

## 25. WASTE DISPOSAL

Packaging materials (paper and wood) can be burned in the boiler. PP tape, unburned remains and ash shall be managed as communal waste.

When the lifespan of the boiler expires, liquidate its body and grates as metal waste. Insulation material shall be taken to an appropriate collection location.

The wooden laths are designed for one-time use and cannot be reused as such. Their removal is governed by Act No. 185/2001 Coll., on Waste and on changes of some other Acts, as amended. Used packaging material complies with the requirements for packages specified by Act No. 477/2001 Sb., on Packages and on changes of some other Acts, as amended.

## 26. WARRANTY CONDITIONS

1. H4eko boilers can be installed only by a company with a valid authorization to perform its installation and maintenance.
2. Installation project must be elaborated in accordance with applicable regulations.
3. The heating system must be filled with water, which meets the requirements of ČSN 07 7401 and especially its hardness must not exceed the required parameters. Using antifreeze fluids is not recommended by the manufacturer.
4. Connecting the boiler to the system must be done in accordance with applicable regulations and standards.
5. The flue gas path must be checked by chimney-sweeper before commissioning of the boiler. Require an audit report covering the basic parameters of the flue gas path, including the diameter of the chimney, its length and chimney draft.

6. Flue should not be longer than one meter (distance between the boiler and chimney inlet) and should be fitted with a cleaning opening. The flue can be extended only if the chimney draft was measured and recorded no longer than 30 cm from the boiler outlet and it meets the minimum operating draft, see chapter Main parameters.
7. H4eko boiler must be installed in a separate boiler room, specially adapted for heating. The boiler room must have sufficient space for installation and maintenance of the boiler. There must be sufficient circulation of fresh air for combustion. The boiler must never be installed in open spaces or balconies, in areas inhabited by people. Such as kitchen, living room, bathroom, bedroom, also in areas where there are explosive and flammable materials.
8. It is recommended to install the boiler on a concrete base from fire-proof material. There should be guaranteed minimum handling area around boiler and pellet hopper. 60cm rear and lateral sides, 100cm from the front of the boiler and hopper.
9. When installing and operating the boiler it is necessary to keep a safe distance of 200 mm from flammable materials.
10. It is disallowed to store fuel behind the boiler or next to the boiler within a distance smaller than 800 mm.
11. It is interdicted to store the fuel between two boilers in the boiler room.
12. We recommend to keep the distance between the boiler and fuel min. 1000 mm or store the fuel in a different room.
13. Guarantee fuel tyepes are brown coal and wood logs.
14. Boiler manufacturer is responsible for fuel quality in terms of combustion quality, the amount of ash, intervals for cleaning. These facts only affect the external factors such as the quality of pellets, dust and moisture in the pellets, chimney draft and correct setting of the combustion process.
15. To ignite pellets it is forbidden to use flammable liquids (gasoline, alcohol, etc.).
16. During the boiler operation it is forbidden to overheat it. Maximal CH temperature should be 85°C.
17. If there is a danger of development and penetration of combustibile vapors or gases into the boiler room, or during works with temporarily developed fire or explosion danger (gluing the floorings, painting with combustibile paints etc.), boiler must be put out of operation.
18. Upon completion of the heating season, it is necessary to clean the boiler including flue. The boiler room must be kept clean and dry.
19. It is forbidden to interfere with construction and electrical installation of the boiler.
20. Manufacturer is not liable for damage caused by improper adjustments or setup or improper handling of the product.
21. Wear parts are not covered by the standard warranty period. These parts are: sealing cord, shamot bricks. These parts, however, perform for a long time if the boiler and its components are operated in accordance with the instruction manual.
22. The manufacturer is not responsible for rust on the boiler and its components, since it is always and only caused by external influences, as the humidity in the room, in the fuel or due to improper installation without boiler protection against low-temperature corrosion.
23. Boiler must be protected against low return temperature via a valve, which prevents the cold water going back to the boiler. Minimum acceptable return water temperature is set by the manufacturer at 55 ° C.
24. The manufacturer is not responsible for the condensation of cold air in the flue path, since this must be prevented by proper installation of flue gas path and by the correct setting of the combustion processes.
25. The manufacturer is not responsible for the leakage of smoke from the boiler into the room in case that this is caused due to low chimney draft, incorrect installation of the boiler, or incorrect setting of the combustion process.
26. The manufacturer is not liable for damage caused by handling, shipments, incorrect settings or improper use or other external factors, which are not directly caused by the individual components operation.
27. Installation company that sold the boiler to the end customer is always responsible for proper installation, boiler setup and activation.
28. In the event, it was agreed to maintain the warranty conditions by a third party subject (eg. startup company), then it must be so agreed on three sides, by sales representative, installer and the end customer. All mentioned subjects must agree with this and must be included with signatures in the appendix of warranty card.

**27. WARRANTY CARD****Solid fuel boiler H416EKO-D, H420EKO-D, H425EKO-D****Producer:** OPOP spol. s r.o., Valašské Meziříčí**Tel.:** 571 675 589, **fax.:** 571 611 225

Date of the expedition from the factory : \_\_\_\_\_

The user shall be obliged to have a professional service company to put the device into operation, to conduct regular maintenance and repairs. This warranty card includes quality and completeness certificate. The manufacturer confirms that the product has been inspected and that its design complies with the technical conditions and ČSN EN 303-5. We provide a quality and workmanship warranty for the boiler for the duration of 24 months from the date of its sale to the given consumer, however, 30 months, at the most, from the moment of releasing the product from production facility. Under the warranty conditions, we will correct all defects demonstrably caused by faulty material, faulty design or faulty production as soon as possible and at our own expense, provided that:

- The boiler is in normal technical conditions pursuant to the operating manual;
- boiler and all additional devices are installed and operated in accordance with standards and laws in given State
- The boiler is connected to a chimney flue in accordance with ČSN 73 4201:1989;
- The boiler has not been mechanically damaged by force (no unauthorized intervention has been conducted with the exception of interventions permitted in the operating manual);
- A chimney draft pursuant to ČSN 303-5 that corresponds to the value stated in this standard (Picture 2, page 26, based on the boiler type);
- The customer, when exercising his/her warranty claim, submits this, duly completed, warranty card;
- All instructions of the manufacturer for using pressurized expansion containers are fulfilled.
- If the consumer does not sell the product within the above stated warranty period, the consumer shall bear all responsibility for any defect of the product;
- Expenses related to the processing of the warranty claim shall be covered by the consumer;
- Insulation for the stoking door and the fireclay board are considered consumer products that cannot be covered by this warranty.

TK date: \_\_\_\_\_

Sale date: \_\_\_\_\_

## 28. DECLARATION OF CONFORMITY

**NÁVRH PŮVODNÍHO ES A EU PROHLÁŠENÍ O SHODĚ**

dle směrnice Evropského parlamentu a Rady 2006/42/ES (nařízení vlády č. 176/2008 Sb.)  
 dle směrnice Evropského parlamentu a Rady 2014/35/EU (nařízení vlády č. 118/2016 Sb.)  
 dle směrnice Evropského parlamentu a Rady 2014/30/EU (nařízení vlády č. 117/2016 Sb.)

**Výrobce :** OPOP spol. s.r.o.  
 Zašovská 750  
 757 01

**Zařízení:** TEPLOVODNÍ KOTEL S RUČNÍM PŘIKLÁDÁNÍM

**Typové označení:** H416EKO-D

**Popis zařízení:** Výrobek H416EKO-D je ocelový svařovaný teplovodní kotel určený k ústřednímu vytápění bytů, rodinných domků a podobných objektů.

**splňuje požadavky:**

Směrnice 2006/42/ES ( nařízení vlády č. 176/2008 Sb.)

Směrnice 2014/35/EU (Nařízení vlády č. 118/2016 Sb.)

Směrnice 2014/30/EU (Nařízení vlády č. 117/2016 Sb.)

**Seznam harmonizovaných norem použitých při posuzování shody:**

ČSN EN 303-5:201, ČSN 06 1008:1997, ČSN EN 60335-1 ed. 3:2012, ČSN EN 60335-2-102:2007  
 ČSN EN 55014-1:2007 ed.3 ČSN EN 61000-6-3 ed.2 :2007, ČSN EN 61000-3-2 ed.3 :2006, ČSN EN  
 61000-3- ed. 2 3:2009, ČSN EN 61000-6-2 ed 3:2006 ed 3, ČSN EN 62233:2008, ČSN EN ISO  
 12100:2011, ČSN EN ISO 14120:2017, ČSN EN ISO 11202:2010 ČSN EN ISO 3746:2011, ČSN EN  
 15036-1:2007 a ČSN EN ISO 13857:2008

**Seznam dalších technických norem a předpisů:**

Certifikát SZÚ, s.p. Brno

**Osoba oprávněná k vypracování původního ES a EU prohlášení o shodě:**

Toto prohlášení o shodě je původní ES a EU prohlášení o shodě.

**Poslední dvojčíslí roku, v němž bylo označení CE na výrobek umístěno: 18**

Ve Valašském Meziříčí

dne 23.8.2018

Mikuda Jan



.....  
 Osoba pověřena vypracováním  
 původního ES prohlášení o shodě

ing. Michal Dostál



.....  
 identifikace osoby mající  
 zmocnění k podpisu za výrobce





OPOP, spol. s r. o.

Zašovská 750

757 01 Valašské Meziříčí

Bankovní spojení:

Komerční banka a.s., č. účtu: 1608851/0100

IČO: 47674105, DIČ: CZ 47674105

Telefon: obchodní oddělení: 571 675 589, sekretariát: 571 611 250, výroba: 571 675 405

Zásobování: 571 675 114, finanční oddělení: 571 675 472

Fax. 571 611 225